

WT 530

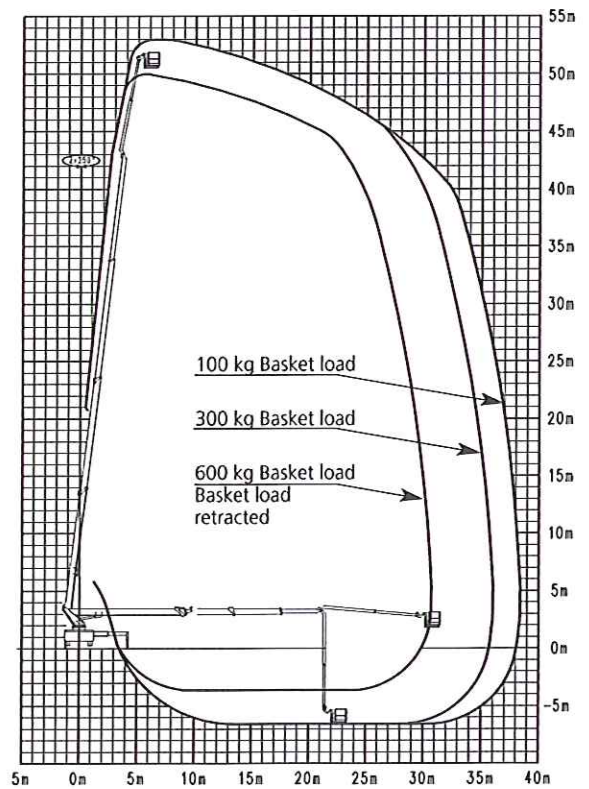

WT 530 Working range

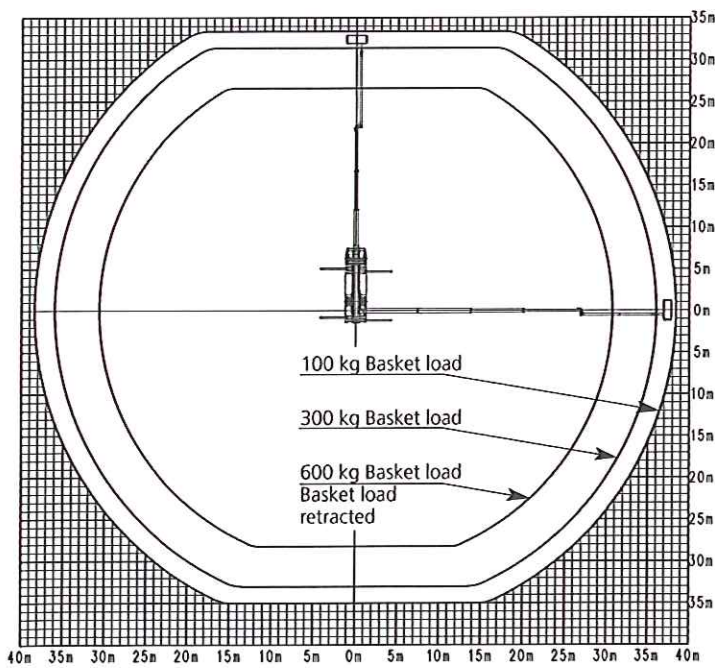

High Nominal Load

Technical Data WT 530

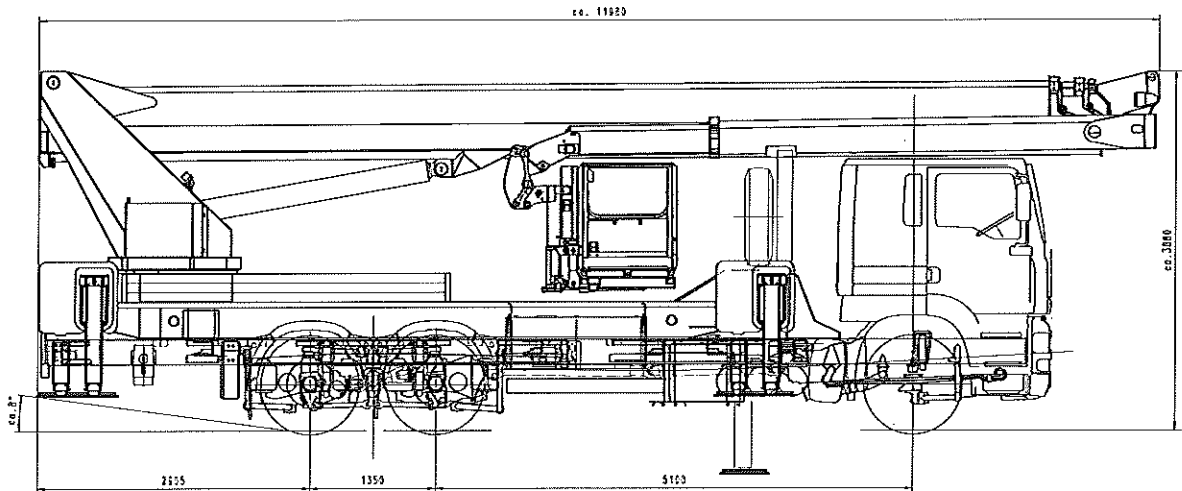

Specifications of basic model

Max. working height	53 m
Max. basket floor height	51 m
Max. horizontal outreach of telescopic workman basket (with ... kg basket load)	38.3 m / 100 kg
Max. horizontal reach Heavy-duty workman basket (with ... kg basket load)	39 m / 100 kg

Workman basket

Standard basket:	3.88 x 1.05 x 1.10 m
Telescopic basket (WxLxH)	
Optional basket:	2.47 x 1.05 x 1.10 m
Heavy-duty basket (WxLxH)	
Outreach with straight position of basket	30 m / 100 kg
Slewing range of basket	2 x 80°
Max. permissible load with fully extended jib boom	
Telescopic basket	300 kg
Heavy-duty basket	400 kg
Max. permissible load when jib boom is not extended	
Telescopic basket	600 kg
Heavy-duty basket	700 kg
Motor Start/Stop in the workman basket	standard
Synthetic cover on control panel	standard
230 V CEE outlet in the workman basket	standard
5 anchor points to secure safety belt	standard
Displaceable control panel	standard
Graphic display	standard
Reversible slewing direction after panel relocation	standard
Collision protection for basket and jib boom	standard
Battery voltage monitoring in the basket	standard

Stabilizers

Function of the stabilizers	fully variable
Max. stabilizer spread - both sides horizontally extended	8.67 m
Stabilizer control at the base	standard
Automatic outrigger system and set-up levelling	standard
Max. permissible inclination 2°	
Blinking lights on the stabilizer extensions	standard
4 Safety plates	standard

Boom system

Number of extensions (main boom)	3
Jib boom	1 extension
Max. length of jib boom	8.5 m
Working range with jib boom below floor level	up to 6 m
All power guides and hydraulic and mechanical equipment internally routed and optimally protected against damage	standard
Hydraulic jib boom, working range	175°
Automatic return of main boom to transport position "Home Function"	standard

Slewing system

Slewing within mirror width	standard
Slewing range	540°

Carrier vehicle and installation

GVW class	at least 26 t
Length in transport position	12 m*
Width in transport position	2.50 m*
Height in transport position	3.90 m*
Angle of slope	approx. 8°*
Hydraulic oil tank with return line filter	standard

*) depending on carrier vehicle

Manual and emergency controls

Integrated in the body - well-protected and lockable	standard
Emergency lowering system in the basket	standard
Back-up/Emergency control at the base	standard
24 V electric emergency pump over vehicle battery	standard